

CL100 Series
Part Number: 7807

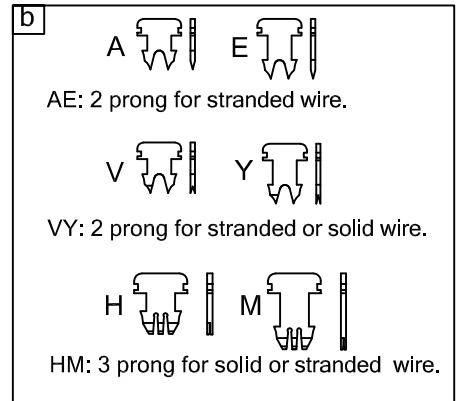
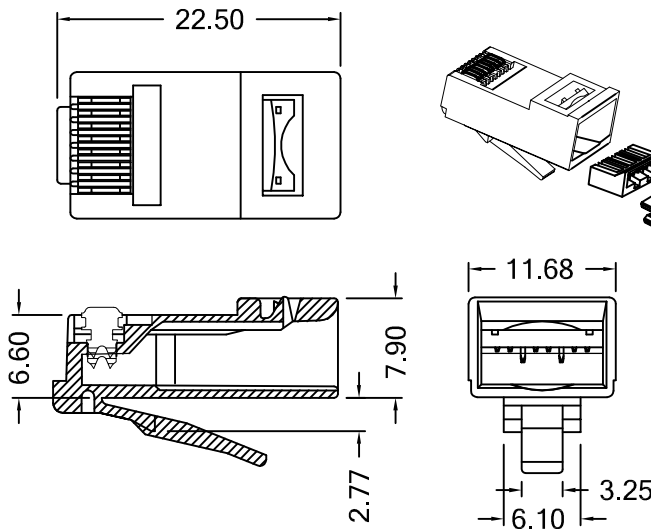

MATERIAL & FINISH

Body: PC. UL94V-2 or UL94V-0, clean
Contact: copper alloy, underplated nickel, and hard gold plated on contact region, gold flash on remainder of terminal.

MECHANICAL SPECIFICATIONS

Operating Temperature: -40°C to 85°C
Mating Cycles: 750 cycles min.

ELECTRICAL SPECIFICATIONS

Voltage: 125 VAC
Current: 1.5 A
Contact Resistance: 30 milliohms max.
Insulation Resistance: 500 megaohms min.
Dielectric Withstanding Voltage: 1000 VAC

ORDERING INFORMATION

7807 A H 8 8 8 a b c + d

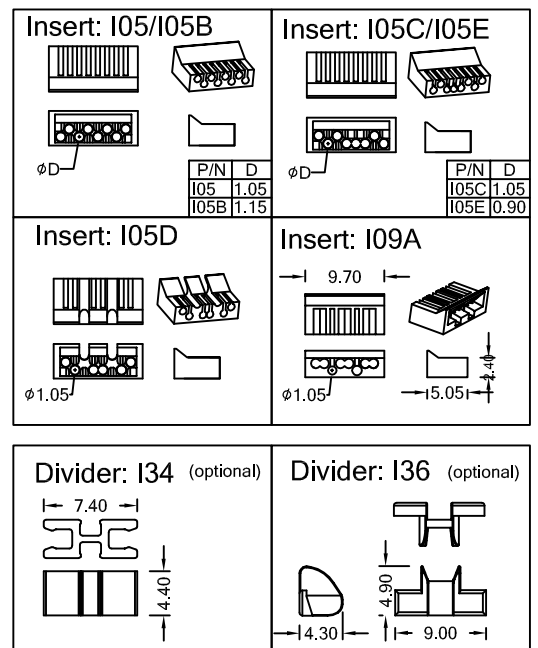
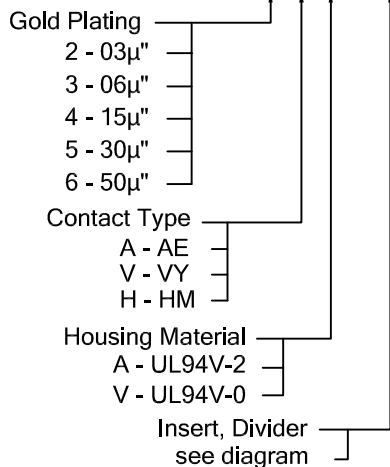

Unit: m/m

Tol.: ±0.15 unless otherwise stated



巨亮企業有限公司
CHU LIANG ENTERPRISE CO.,LTD.

TEL:886-2-22023997 FAX:886-2-22023867

E-mail: web@plug.com.tw
peter@plug.com.tw

Web: http://www.plug.com.tw